

DIMENSIONS TABLE											
MODEL	PORT SIZE	HEIGHT (H)		WIDTH(W)		DEPTH (D)		FIXING HOLE SPACING (d1)		WEIGHT	
		mm	Inches	mm	Inches	mm	Inches	mm	Inches	Kg	lbs
OVRP350	2"	1062	41.8	538	21.2	550	21.7	388	15.3	67	147
OVRP400	2.5"	1062	41.8	682	26.9	550	21.7	508	20.0	93	205
OVRP450	2.5"	1062	41.8	836	32.9	550	21.7	646	25.4	121	267
OVRP500	2.5"	1062	41.8	1005	39.6	550	21.7	815	32.1	144	318
OVRP550	2.5"	1062	41.8	1174	46.2	550	21.7	984	38.7	171	377

NOTES
 1) FLANGE PLATES CAN BE EITHER BSPP OR NPT
 2) ENSURE CLEARANCE OF 800mm ABOVE UNIT FOR SERVICE OF CARTRIDGE

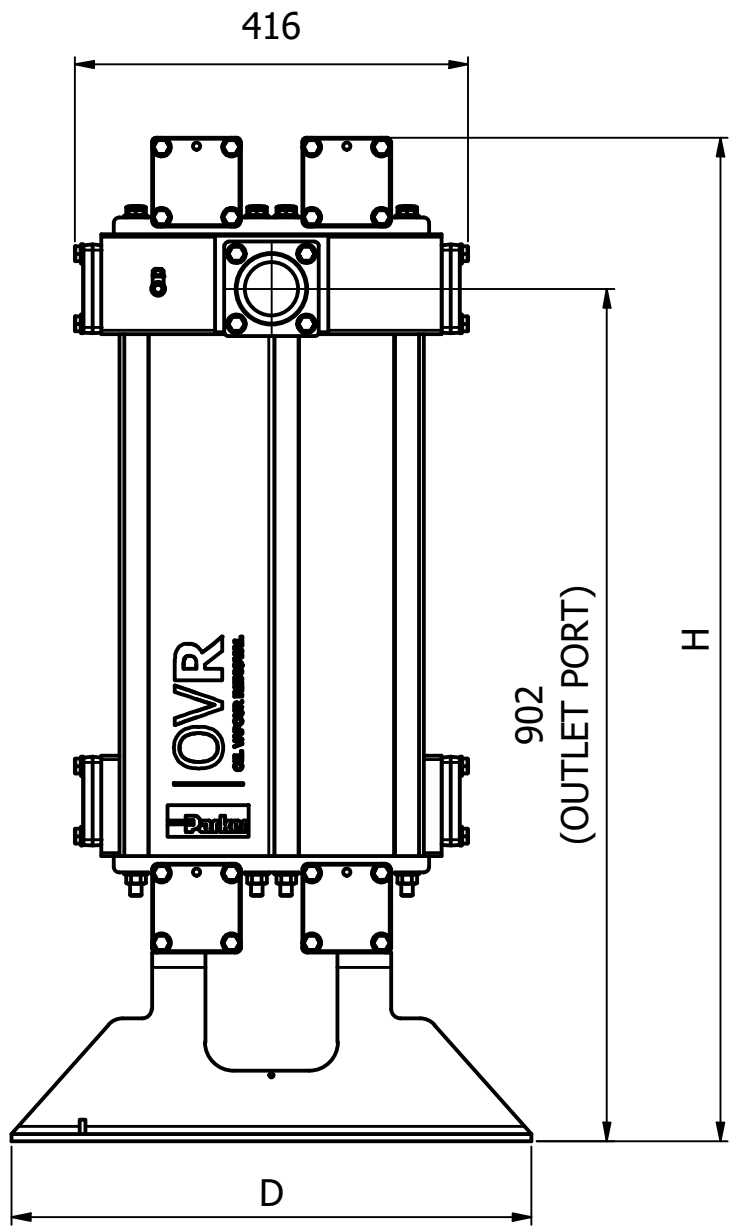
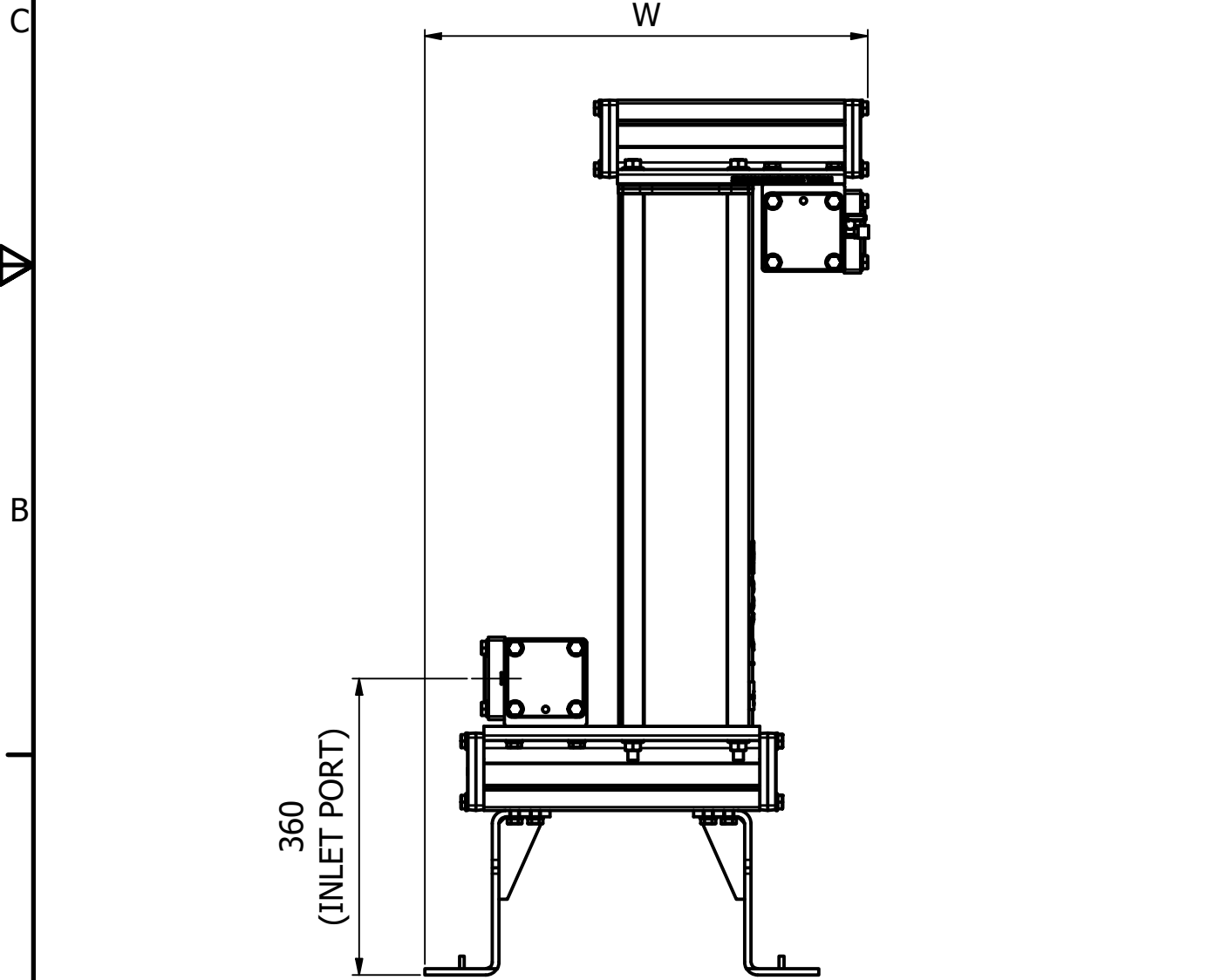

ECO No. 0373009 REV A

PLEASE CONSIDER THE ENVIRONMENT PRIOR TO PRINTING THIS DRAWING

DO NOT SCALE - IF IN DOUBT ASK

BASED ON BS 8888 DIMENSIONS IN MILLIMETRES

GENERAL TOLERANCES UNLESS OTHERWISE STATED

MACHINED DIMENSIONS
 .XX ±0.13 UP TO 300 ±0.3
 .X ±0.25 OVER 300 TO 600 ±0.5

POSITIONAL TOLERANCE
 PLAIN HOLES Ø0.13
 TAPPED HOLES Ø0.26
 CONCENTRICITY TOLERANCE 0.13 TIR

MACHINED SURFACES INDICATED THUS
 SURFACE TEXTURE TO BS 1134
 VALUES IN MICROMETRES

ANGLES ±1/2° (EXCEPT CHAMFERS)

METRIC THREADS TO BS 3643 MED. CLASS
 EXTERNAL 6g INTERNAL 6H
 PIPE THREADS
 PRESSURE TIGHT TO BS 21

SHEET METALWORK & FABRICATIONS
 SHEET METALWORK DIMENSIONS
 UP TO 500 ±0.5
 OVER 500 TO 1000 ±1.0
 OVER 1000 ±1.5

FABRICATED PARTS DIMENSIONS
 UP TO 500 ±2
 OVER 500 TO 1000 ±4
 OVER 1000 ±6

POSITIONAL TOLERANCE FOR PLAIN & TAPPED HOLES
 UP TO 500 Ø1.0
 OVER 500 Ø2.0



Parker Hannifin Manufacturing Ltd
 Filtration & Separation Division
 Dukesway, Team Valley
 Gateshead, Tyne & Wear
 England, NE11 0PZ
 TEL +44 (0)191 402 9000
 FAX +44 (0)191 482 6296
 www.parker.com/dhfn

THIS DOCUMENT IS COPYRIGHT AND IS THE PROPERTY OF PARKER HANNIFIN LTD. IT MUST NOT BE COPIED IN WHOLE OR PART, USED FOR MANUFACTURE OF, OR OTHERWISE DISCLOSED WITHOUT PRIOR WRITTEN CONSENT OF THE COMPANY

MATERIAL GEN. ARRT	SCALE 1:8		DRAWN CL	CHECKED DTR	APPROVED KW	TITLE OVRP350-550 SALES DRAWING	DRG No. 101-10771	SHEET 1 / 1
			DATE 15/06/2021	DATE 15/06/2021	DATE 15/06/2021			